



BXUV.V496

Design/System/Construction/Assembly Usage Disclaimer

- Authorities Having Jurisdiction should be consulted in all cases as to the particular requirements covering the installation and use of UL Certified products, equipment, system, devices, and materials.
- Authorities Having Jurisdiction should be consulted before construction.
- Fire resistance assemblies and products are developed by the design submitter and have been investigated by UL for compliance with applicable requirements. The published information cannot always address every construction nuance encountered in the field.
- When field issues arise, it is recommended the first contact for assistance be the technical service staff provided by the product manufacturer noted for the design. Users of fire resistance assemblies are advised to consult the general Guide Information for each product category and each group of assemblies. The Guide Information includes specifics concerning alternate materials and alternate methods of construction.
- Only products which bear UL's Mark are considered Certified.

BXUV - Fire Resistance Ratings - ANSI/UL 263 Certified for United States

BXUV7 - Fire Resistance Ratings - CAN/ULC-S101 Certified for Canada

[See General Information for Fire-resistance Ratings - ANSI/UL 263 Certified for United States Design Criteria and Allowable Variances](#)

[See General Information for Fire Resistance Ratings - CAN/ULC-S101 Certified for Canada Design Criteria and Allowable Variances](#)

Design No. V496

December 01, 2020

Nonbearing Wall Rating — 1 or 2 Hr.

*** Indicates such products shall bear the UL or cUL Certification Mark for jurisdictions employing the UL or cUL Certification (such as Canada), respectively.**

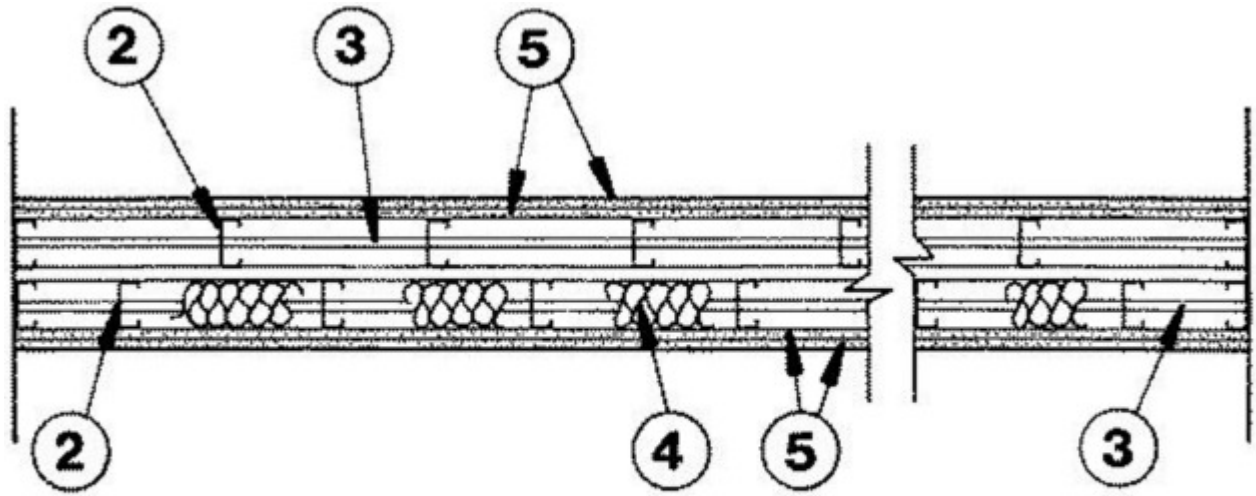

HORIZONTAL SECTION

1. Floor and Ceiling Runners — For use with Item 5. Channel shaped, attached to floor and ceiling in two rows, a min 1 in. apart, with steel fasteners spaced 24 in. OC. Runners fabricated from min No. 25 MSG galv steel, 1-1/4 in. wide and 2-1/2 in. deep.

1A. Floor and Ceiling Runners — (Not Shown) — As an alternate to Item 1, For use with Items 5, 5A, 5B, or 5C - Channel shaped, attached to floor and ceiling in two rows, a min 1 in. apart. Runners fabricated from min No. 20 MSG galv steel, 1-3/16 in. wide and 2-9/16 in. deep.

1B. Framing Members* — Floor and Ceiling Runners — (Not Shown) — As an alternate to Item 1, For use with Item 5 - Channel shaped, min 2-1/2 in. deep fabricated from min 0.018 in. thick galv steel, attached to floor and ceiling with fasteners 24 in. OC. max.

CLARKDIETRICH BUILDING SYSTEMS — CD ProTRAK

DMFCWBS L L C — ProTRAK

MBA METAL FRAMING — ProTRAK

RAM SALES L L C — Ram ProTRAK

STEEL STRUCTURAL PRODUCTS L L C — Tri-S ProTRAK

1C. Framing Members* — Floor and Ceiling Runner — (Not Shown) — As an alternate to Item 1, For use with Item 5 - proprietary channel shaped runners, min 2-1/2 in. deep with 1-1/4 in. long legs fabricated from min 0.018 in. thick galv steel, attached to floor and ceiling with fasteners spaced 24 in. OC max.

CALIFORNIA EXPANDED METAL PRODUCTS CO — Viper20™ Track

MARINO/WARE, DIV OF WARE INDUSTRIES INC — Viper20™ Track

FUSION BUILDING PRODUCTS — Viper20™ Track

IMPERIAL MANUFACTURING GROUP INC — Viper20™ Track

1D. Framing Members* — Floor and Ceiling Runners — (Not Shown) — As an alternate to Item 1, For use with Item 5 - Channel shaped, min. 2-1/2 in. deep, attached to floor and ceiling with fasteners 24 in. OC. max.
ALLSTEEL & GYPSUM PRODUCTS INC — Type SUPREME D24/30EQD and Type SUPREME D20

CONSOLIDATED FABRICATORS CORP, BUILDING PRODUCTS DIV — Type SUPREME D24/30EQD and Type SUPREME D20

QUAIL RUN BUILDING MATERIALS INC — Type SUPREME D24/30EQD and Type SUPREME D20

SCAFCO STEEL STUD MANUFACTURING CO — Type SUPREME D24/30EQD and Type SUPREME D20

STEEL CONSTRUCTION SYSTEMS INC — Type SUPREME D24/30EQD and Type SUPREME D20

TELLING INDUSTRIES L L C — Type SUPREME D24/30EQD and Type SUPREME D20

UNITED METAL PRODUCTS INC — Type SUPREME D24/30EQD and Type SUPREME D20

1E. Framing Members* — Floor and Ceiling Runner — (Not Shown) — As an alternate to Item 1, For use with Item 5 - proprietary channel shaped runners, min 2-1/2 in. deep with 1-1/4 in. long legs fabricated from min 0.018 in. thick galv steel, attached to floor and ceiling with fasteners spaced 24 in. OC max.

TELLING INDUSTRIES L L C — Viper20™ Track

1F. Framing Members* — Floor and Ceiling Runner — (Not Shown) — As an alternate to Item 1, For use with Item 2G and Item 5 - proprietary channel shaped runners, min 3-1/2 in. deep with 1-1/4 in. long legs fabricated from min 0.018 in. thick galv steel, attached to floor and ceiling with fasteners spaced 24 in. OC max.

RESCUE METAL FRAMING, L L C — AlphaTRAK

1G. Framing Members* — Floor and Ceiling Runner — (Not Shown) — As an alternate to Item 1, For use with Item 2H and Item 5 - proprietary channel shaped runners, min 2-1/2 in. deep with 1-1/4 in. long legs fabricated from min 25 MSG (0.018 in. min. bare metal thickness), attached to floor and ceiling with fasteners spaced 24 in. OC max.

CALIFORNIA EXPANDED METAL PRODUCTS CO — Viper X Track

1H. Framing Members* — Floor and Ceiling Runner — (Not Shown) — As an alternate to Item 1, For use with Item 5 - proprietary channel shaped runners, min 2-1/2 in. deep with 1-1/4 in. long legs fabricated from min 0.020 in. thick galv steel, attached to floor and ceiling with fasteners spaced 24 in. OC max.

CRACO MFG INC — SmartTrack20™

2. Steel Studs — For use with Item Items 1 and 5. Channel shaped, supplied with cutouts, friction -fitted into floor and ceiling runners and spaced a max 24 in. OC. Studs cut 1/2 in. less than assembly height and evenly staggered between the two rows of floor and ceiling runners. Studs fabricated from min No. 25 MSG galv steel, min 2-1/2 in. deep by 1-5/8 in. wide with 3/8 in. folded back return flange legs.

2A. Steel Studs — (Not Shown) — As an alternate to Item 2, For use with Items 1A, 5, 5A, 5B, or 5C. Channel shaped, supplied with cutouts, friction -fitted into floor and ceiling runners and spaced a max 16 in. OC. Studs cut 1/2 in. less than assembly height and staggered flush against the floor runners. Studs fabricated from min No. 20 MSG galv steel, min 2-1/2 in. deep x 1-5/8 in. wide x 3/8 in. folded back return flange legs.

2B. **Framing Members* — Steel Studs** — (Not Shown) — As an alternate to Item 2, For use with Items 1B and 5 - min 2-1/2 in. deep fabricated from min 0.018 in. thick galv steel, spaced a max of 24 in. OC. Studs to be cut 1/2 in. less than assembly height.

CLARKDIETRICH BUILDING SYSTEMS — CD ProSTUD

DMFCWBS L L C — ProSTUD™

MBA METAL FRAMING — ProSTUD

RAM SALES L L C — Ram ProSTUD

STEEL STRUCTURAL PRODUCTS L L C — Tri-S ProSTUD

2C. **Framing Members* — Steel Studs** — (Not Shown) — As an alternate to Item 2, For use with Items 1C and 5 —proprietary channel shaped steel studs, 1-1/4 in. wide by min 2-1/2 in. deep, fabricated from min 0.018 in. thick galv steel, spaced 24 in. OC. Studs cut 1/2 in. less in length than assembly height.

CALIFORNIA EXPANDED METAL PRODUCTS CO — Viper20™

MARINO/WARE, DIV OF WARE INDUSTRIES INC — Viper20™

FUSION BUILDING PRODUCTS — Viper20™

IMPERIAL MANUFACTURING GROUP INC — Viper20™

2D. **Framing Members* — Steel Studs** — (Not Shown) — As an alternate to Item 2, For use with Items 1D and 5 - Channel shaped studs, min. 2-1/2 in. deep, spaced a max of 24 in. OC. Studs to be cut 1/2 in. less than assembly height.

ALLSTEEL & GYPSUM PRODUCTS INC — Type SUPREME D24/30EQD and Type SUPREME D20

CONSOLIDATED FABRICATORS CORP, BUILDING PRODUCTS DIV — Type SUPREME D24/30EQD and Type SUPREME D20

QUAIL RUN BUILDING MATERIALS INC — Type SUPREME D24/30EQD and Type SUPREME D20

SCAFCO STEEL STUD MANUFACTURING CO — Type SUPREME D24/30EQD and Type SUPREME D20

STEEL CONSTRUCTION SYSTEMS INC — Type SUPREME D24/30EQD and Type SUPREME D20

TELLING INDUSTRIES L L C — Type SUPREME D24/30EQD and Type SUPREME D20

UNITED METAL PRODUCTS INC — Type SUPREME D24/30EQD and Type SUPREME D20

2E. **Framing Members* — Steel Studs** — (Not Shown) — As an alternate to Item 2, For use with Items 1E and 5 —proprietary channel shaped steel studs, 1-1/4 in. wide by min 2-1/2 in. deep, fabricated from min 0.018 in. thick galv steel, spaced 24 in. OC. Studs cut 1/2 in. less in length than assembly height.

TELLING INDUSTRIES L L C — Viper20™

2F. **Framing Members* — Steel Studs** — As an alternate to Item 2 — For use with Item 1C (3-5/8 in. wide track), channel shaped studs, fabricated from min 25 MSG corrosion-protected steel, 1-1/4 in. wide by 3-5/8 in. deep, spaced a max of 24 in. OC. Studs to be cut 3/8 to 3/4 in. less than assembly height.

MARINO/WARE, DIV OF WARE INDUSTRIES INC — StudRite™

2G. **Framing Members* — Steel Studs** — As an alternate to Item 2, For use with Items 1F and 5 —proprietary channel shaped steel studs, 1-1/4 in. wide by min 3-1/2 in. deep, fabricated from min 0.018 in. thick galv steel, spaced 24 in. OC. Studs cut 1/2 in. less in length than assembly height.

RESCUE METAL FRAMING, L L C — AlphaSTUD

2H. **Framing Members* — Steel Studs** — (Not Shown) — As an alternate to Item 2, For use with Items 1G and 5 — proprietary channel shaped steel studs, min 2-1/2 in. deep by 1-5/8 in. wide, fabricated from min 25 MSG (0.018 in. min. bare metal thickness), spaced 24 in. OC. Studs cut 1/2 in. less in length than assembly height.

CALIFORNIA EXPANDED METAL PRODUCTS CO — Viper X

2I. **Framing Members* — Steel Studs** — (Not Shown) — As an alternate to Item 2, For use with Items 1H and 5 —proprietary channel shaped steel studs, 1-1/4 in. wide by min 2-1/2 in. deep, fabricated from min 0.020 in. thick galv steel, spaced 24 in. OC. Studs cut 1/2 in. less in length than assembly height.

CRACO MFG INC — SmartStud20™

3. **Lateral Bracing** — The bracing shall be in accordance with the SSMA Technical Note Dated March 2000 Referencing Unsheathed Flange Bracing.

3A. **Lateral Bracing** — (Not Shown) — Right angle- shaped, supplied with notches spaced 12, 16, or 24 in. OC., friction-fitted to the cutouts in steel studs, supplied in 7/8 in. by 7/8 in. by 50 in. lengths. Lateral bracing bars fabricated from min. 20 MSG galvanized steel. The bracing shall be located a maximum of 5 ft on center in accordance with the manufacturers published literature.

CLARKDIETRICH BUILDING SYSTEMS — TradeReady Spazzer 9200 bar

4. **Batts and Blankets** — Optional — Glass fiber batts may be friction-fitted to completely fill the stud cavities on one or both rows of studs.

See **Batts and Blankets Category** (BZJZ) for names of manufacturers.

5. **Gypsum Board*** — Nom 5/8 in. thick, 4 ft. wide, gypsum panels with beveled, square or tapered edges, applied vertically. Single layer installed on each side of the steel studs for the 1-hr system, two layers installed on each side of the studs for the 2-hr system. Vertical joints centered over studs and staggered one stud cavity on opposite sides of studs. Vertical joints in adjacent layers (2-hr system) staggered one stud cavity. For the single layer system: panels attached to steel studs and floor runner with 1 in. long Type S or S-12 steel screws spaced 8 in. OC along vertical and bottom edges and 12 in. OC in the field. For the double layer system: base layer panels attached to steel studs and floor runner with 1 in. long Type S or s-12 steel screws spaced 16 in. OC, face layer panels attached to steel studs and floor runner with 1-5/8 in. long Type S or S-12 steel screws spaced 12 in. OC

When **Steel Framing Members*** (Item 7) are used: For the 1-hr system, gypsum panels attached vertically to furring channels with 1 in. long Type S-12 screws spaced 12 in. OC. Vertical joints offset min 12 in. from layer on other side of wall. For the 2-hr system, inner layer of gypsum panels attached vertically to furring channels with 1 in. Type S-12 screws spaced 16 in. OC, outer layer with 1-5/8 in. Type S-12 screws spaced 12 in. OC. Inner layer to be applied vertically. Outer layer to be applied vertically with joints offset a minimum 12 in. from inner layer joints.

AMERICAN GYPSUM CO — Types AGX-1, M-Glass, AG-C, LightRoc

5A. **Gypsum Board*** — (Not Shown) — As an alternate to Item 5, may be used as the base layer on one or both sides of wall. For direct attachment only to Items 1A and 2A. - Nom 5/8 in. thick lead backed gypsum panels with beveled, square or tapered edges, applied vertically. Vertical joints centered over studs and staggered min 1 stud cavity on opposite sides of studs. Gypsum board secured to studs with 1-1/4 in. long Type S-12 steel screws spaced 8 in. OC at perimeter and 12 in. OC in the field.

RAY-BAR ENGINEERING CORP — Type RB-LBG

5B. **Gypsum Board*** — (Not Shown) — As an alternate to Item 5, may be used as the base layer on one or both sides of wall. For direct attachment only to Items 1A and 2A) - Nominal 5/8 in. thick lead backed gypsum panels with beveled, square or tapered edges, applied vertically. Vertical joints centered over studs and staggered min 1 stud cavity on opposite sides of studs. Wallboard secured to studs with 1-1/4 in. long Type S-12 (or #6 by 1-1/4 in. long bugle head fine driller) steel screws spaced 8 in. OC at perimeter and 12 in. OC in the field.

NEW ENGLAND LEAD BURNING CO INC, DBA NELCO — Nelco

5C. **Gypsum Board*** — (As an alternate to Item 5 when used as the base layer on one or both sides of wall, For direct attachment only to Items 1A and 2A) — Nom 5/8 in. thick lead backed gypsum panels with beveled, square or tapered edges, applied vertically. Vertical joints centered over studs and staggered min 1 stud cavity on opposite sides of studs. Wallboard secured to studs with 1-1/4 in. long Type S-12 steel screws spaced 8 in. OC at perimeter and in the field when applied as the base layer. Lead batten strips required behind vertical joints of lead backed gypsum wallboard and optional at remaining stud locations. Lead batten strips, min 2 in. wide, max 10 ft long with a max thickness of 0.140 in. placed on the face of studs and attached to the stud with two 1 in. long Type S-8 pan head steel screws, one at the top of the strip and one at the bottom of the strip. Lead discs, max 5/16 in. diam by max 0.140 in. thick compression fitted or adhered over the screw heads. Lead batten strips and discs to have a purity of 99.9% meeting the Federal specification QQ-L-201f, Grades "A, B, C or D". Fasteners for face layer gypsum panels (Items 5) when installed over lead backed board to be min 2-1/2 in. Type S-12 bugle head steel screws.

MAYCO INDUSTRIES INC — "X-Ray Shielded Gypsum"

6. **Joint Tape and Compound** — (Not Shown) — Vinyl or casein, dry or premixed joint compound applied in two coats to joints and screw heads of outer layers. Paper tape, nom 2 in. wide, embedded in first layer of compound over all joints of outer layer panels. Paper tape and joint compound may be omitted when gypsum panels are supplied with a square edge.

7. **Steel Framing Members*** — (Not Shown) — (Optional on one or both sides) for single or double layer systems, may not be used with Items 5A, 5B or 5C. Furring channels and Steel Framing Members as described below:

a. **Furring Channels** — Formed of No. 25 MSG galv steel. 2-9/16 in. or 2-23/32 in. wide by 7/8 in. deep, spaced max. 24 in. OC perpendicular to studs. Channels secured to studs as described in Item b. Gypsum board attached to furring channels as described in Item 5.

b. **Steel Framing Members*** — Used to attach furring channels (Item 7a) to studs (Item 2). Clips spaced max. 48 in. OC., and secured to studs with No. 8 x 1-1/2 in. minimum self-drilling, S-12 steel screw through the center grommet. Furring channels are friction fitted into clips. RSIC-1 clip for use with 2-9/16 in. wide furring channels. RSIC-1 (2.75) clip for use with 2-23/32 in. wide furring channels.

PAC INTERNATIONAL L L C — Types RSIC-1, RSIC-1 (2.75).

7A. **Steel Framing Members*** — (Optional, Not Shown) — — May not be used with Items 5A, 5B, or 5C. Furring channels and Steel Framing Members as described below:

a. **Furring Channels** — Formed of No. 25 MSG galv steel. Spaced 24 in. OC perpendicular to studs. Channels secured to studs as described in Item b. Ends of adjoining channels overlapped 6 in. and tied together with double strand of No. 18 AWG galvanized steel wire. Gypsum board attached to furring channels as described in Item 5.

b. **Steel Framing Members*** — Used to attach furring channels (Item 7Aa) to studs. Clips spaced 48 in. OC., and secured to studs with 2 in. coarse drywall screw with 1 in. diam washer through the center hole. Furring channels are

friction fitted into clips.

STUDCO BUILDING SYSTEMS — RESILMOUNT Sound Isolation Clips - Type A237R

7B. **Steel Framing Members*** — (Optional, Not Shown) — May not be used with Items 5A, 5B, or 5C. Furring channels and Steel Framing Members as described below:

a. **Furring Channels** — Formed of No. 25 MSG galv steel, spaced 24 in. OC, and perpendicular to studs. Channels secured to studs as described in Item b. Ends of adjoining channels overlapped 6 in. and secured in place with a double strand of No. 18 AWG twisted steel wire. Gypsum board attached to furring channels as described in Item 5.

b. **Steel Framing Members*** — Used to attach furring channels (Item 7Ba) to studs. Clips spaced 48 in. OC., and secured to studs with No. 8 x 2-1/2 in. coarse drywall screw through the center hole. Furring channels are friction fitted into clips.

REGUPOL AMERICA — Type SonusClip

7C. **Steel Framing Members*** — (Optional, Not Shown) — May not be used with Items 5A, 5B, or 5C. Resilient channels and Steel Framing Members as described below:

a. **Resilient Channels** — Formed of No. 25 MSG galv steel, spaced 24 in. OC, and perpendicular to studs. Channels secured to studs as described in Item b. Ends of adjoining channels overlapped 6 in. and secured in place with two No. 8 15 x 1/2 in. Philips Modified Truss screws spaced 2-1/2 in. from the center of the overlap. Gypsum board attached to resilient channels as described in Item 5.

b. **Steel Framing Members*** — Used to attach resilient channels (Item 7Ca) to studs. Clips spaced 48 in. OC., and secured to studs with No. 8 x 2-1/2 in. coarse drywall screw through the center hole. Resilient channels are secured to clips with one No. 10 x 1/2 in. pan-head self-drilling screw.

KEENE BUILDING PRODUCTS CO INC — Type RC+ Assurance Clip

8. **Lead Batten Strips** — (Not Shown, For Use With Item 5A) — Lead batten strips, min 1-1/2 in. wide, max 10 ft long with a max thickness of 0.125 in. Strips placed on the interior face of studs and attached from the exterior face of the stud with two 1 in. long Type S-12 pan head steel screws, one at the top of the strip and one at the bottom of the strip. Lead batten strips to have a purity of 99.9% meeting the Federal specification QQ-L-201f, Grade "C". Lead batten strips required behind vertical joints of lead backed gypsum wallboard (Item 5A) and optional at remaining stud locations. Required behind vertical joints.

9. **Lead Discs or Tabs** — (Not Shown, For Use With Item 5A) — Used in lieu of or in addition to the lead batten strips (Item 8) or optional at other locations - Max 3/4 in. diam by max 0.125 in. thick lead discs compression fitted or adhered over steel screw heads or max 1/2 in. by 1-1/4 in. by max 0.125 in. thick lead tabs placed on gypsum boards (Item 5A) underneath screw locations prior to the installation of the screws. Lead discs or tabs to have a purity of 99.9% meeting the Federal specification QQ-L-201f, Grade "C".

10. **Lead Batten Strips** — (Not Shown, For Use With Item 5B) — Lead batten strips, 2 in. wide, max 10 ft long with a max thickness of 0.142 in. Strips placed on the face of studs and attached to the stud with two min. 1 in. long min. Type S-8 pan head steel screws, one at the top of the strip and one at the bottom of the strip or with one min. 1 in. long min. Type S-8 pan head steel screw at the top of the strip. Lead batten strips to have a purity of 99.9% meeting the Federal specification QQ-L-201f, Grade "C". Lead batten strips required behind vertical joints of lead backed gypsum wallboard (Item 5B) and optional at remaining stud locations.

11. **Lead Tabs** — (Not Shown, For Use With Item 5B) — 2 in. wide, 5 in. long with a max thickness of 0.142 in. Tabs friction-fit around front face of stud, the stud folded back flange, and the back face of the stud. Tabs required at each location where a screw (that secures the gypsum boards, Item 5B) will penetrate the steel stud. Lead tabs to have a purity of 99.9% meeting the Federal specification QQ-L-201f, Grade "C". Lead tabs may be held in place with standard adhesive tape if necessary.

12. **Wall and Partition Facings and Accessories*** — (Optional, Not Shown) — For use with Item 5 only — Nominal 1/2 in. thick, 4 ft wide panels, for optional use as an additional layer on one or both sides of the assembly. Panels attached in accordance with manufacturer's recommendations. When the QR-500 or QR-510 panel is installed between the steel framing and the UL Classified gypsum board, the required UL Classified gypsum board layer(s) is/are to be installed as indicated as to fastener type and spacing, except that the required fastener length shall be increased by a minimum of 1/2 in. Not evaluated or intended as a substitute for the required layer(s) of UL Classified Gypsum Board.

PABCO BUILDING PRODUCTS L L C, DBA PABCO GYPSUM — Type QuietRock QR-500 and QR-510

*** Indicates such products shall bear the UL or cUL Certification Mark for jurisdictions employing the UL or cUL Certification (such as Canada), respectively.**

Last Updated on 2020-12-01

The appearance of a company's name or product in this database does not in itself assure that products so identified have been manufactured under UL's Follow-Up Service. Only those products bearing the UL Mark should be considered to be Certified and covered under UL's Follow-Up Service. Always look for the Mark on the product.

UL permits the reproduction of the material contained in the Online Certification Directory subject to the following conditions: 1. The Guide Information, Assemblies, Constructions, Designs, Systems, and/or Certifications (files) must be presented in their entirety and in a non-misleading manner, without any manipulation of the data (or drawings). 2. The statement "Reprinted from the Online Certifications Directory with permission from UL" must appear adjacent to the extracted material. In addition, the reprinted material must include a copyright notice in the following format: "© 2020 UL LLC"