

BXUV.V486

Design/System/Construction/Assembly Usage Disclaimer

- Authorities Having Jurisdiction should be consulted in all cases as to the particular requirements covering the installation and use of UL Certified products, equipment, system, devices, and materials.
- Authorities Having Jurisdiction should be consulted before construction.
- Fire resistance assemblies and products are developed by the design submitter and have been investigated by UL for compliance with applicable requirements. The published information cannot always address every construction nuance encountered in the field.
- When field issues arise, it is recommended the first contact for assistance be the technical service staff provided by the product manufacturer noted for the design. Users of fire resistance assemblies are advised to consult the general Guide Information for each product category and each group of assemblies. The Guide Information includes specifics concerning alternate materials and alternate methods of construction.
- Only products which bear UL's Mark are considered Certified.

BXUV - Fire Resistance Ratings - ANSI/UL 263 Certified for United States

BXUV7 - Fire Resistance Ratings - CAN/ULC-S101 Certified for Canada

[See General Information for Fire-resistance Ratings - ANSI/UL 263 Certified for United States Design Criteria and Allowable Variances](#)

[See General Information for Fire Resistance Ratings - CAN/ULC-S101 Certified for Canada Design Criteria and Allowable Variances](#)

Design No. V486

December 01, 2020

Nonbearing Wall Rating — 1, 2 or 2-1/2 Hr (See Items 1, 1A, 1B, 1C, 2, 2A, 2B, 3 through 3J)

*** Indicates such products shall bear the UL or cUL Certification Mark for jurisdictions employing the UL or cUL Certification (such as Canada), respectively.**

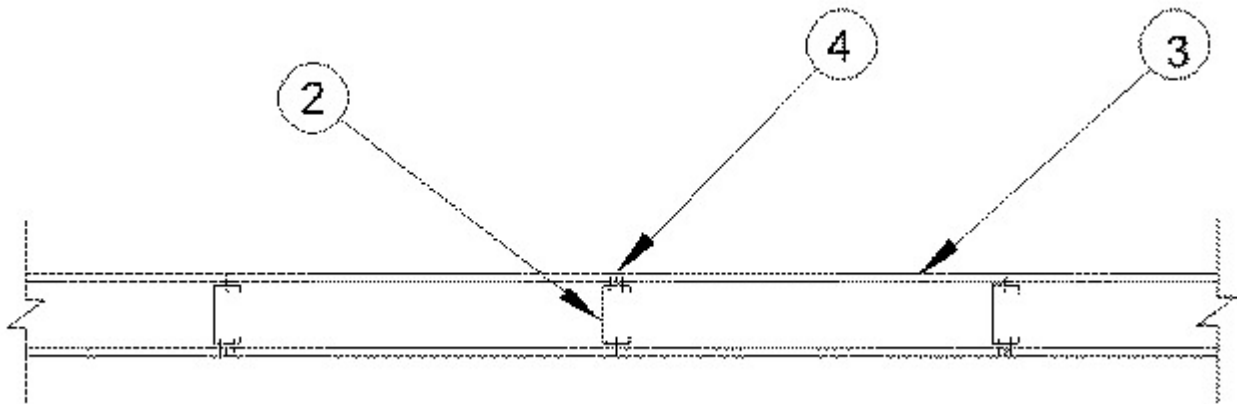

1. Framing Members* — Floor and Ceiling Runners — (Not Shown) — For 1 Hour Rating, channel shaped, min. 3-5/8 in. wide, attached to floor and ceiling with fasteners 24 in. OC max.

ALLSTEEL & GYPSUM PRODUCTS INC — Type SUPREME D24/30EQD and Type SUPREME D20

CALIFORNIA EXPANDED METAL PRODUCTS CO — Viper25™Track

CONSOLIDATED FABRICATORS CORP, BUILDING PRODUCTS DIV — Type SUPREME D24/30EQD and Type SUPREME D20

MARINO/WARE, DIV OF WARE INDUSTRIES INC — Viper25™Track

FUSION BUILDING PRODUCTS — Viper25™ Track

IMPERIAL MANUFACTURING GROUP INC — Viper25™ Track

QUAIL RUN BUILDING MATERIALS INC — Type SUPREME D24/30EQD and Type SUPREME D20

SCAFCO STEEL STUD MANUFACTURING CO — Type SUPREME D24/30EQD and Type SUPREME D20

STEEL CONSTRUCTION SYSTEMS INC — Type SUPREME D24/30EQD and Type SUPREME D20

TELLING INDUSTRIES L L C — Viper25™ Track

TELLING INDUSTRIES L L C — Type SUPREME D24/30EQD and Type SUPREME D20

UNITED METAL PRODUCTS INC — Type SUPREME D24/30EQD and Type SUPREME D20

1A. Framing Members* — Floor and Ceiling Runners — (Not Shown) — For 2 and 2-1/2 Hour Ratings, channel shaped, min. 2-1/2 in. wide, attached to floor and ceiling with fasteners 24 in. OC. max.

ALLSTEEL & GYPSUM PRODUCTS INC — Type SUPREME D24/30EQD and Type SUPREME D20

CONSOLIDATED FABRICATORS CORP, BUILDING PRODUCTS DIV — Type SUPREME D24/30EQD and Type SUPREME D20

QUAIL RUN BUILDING MATERIALS INC — Type SUPREME D24/30EQD and Type SUPREME D20

SCAFCO STEEL STUD MANUFACTURING CO — Type SUPREME D24/30EQD and Type SUPREME D20

STEEL CONSTRUCTION SYSTEMS INC — Type SUPREME D24/30EQD and Type SUPREME D20

TELLING INDUSTRIES L L C — Type SUPREME D24/30EQD and Type SUPREME D20

UNITED METAL PRODUCTS INC — Type SUPREME D24/30EQD and Type SUPREME D20

1B. Framing Members* — Floor and Ceiling Runners — (For use with Items 3B, 3C, 3E and 3F only) — For 2 Hour Rating, min. 1-5/8 in. wide, attached to floor and ceiling with fasteners 24 in. OC. max.

ALLSTEEL & GYPSUM PRODUCTS INC — Type SUPREME D24/30EQD and Type SUPREME D20

CONSOLIDATED FABRICATORS CORP, BUILDING PRODUCTS DIV — Type SUPREME D24/30EQD and Type SUPREME D20

QUAIL RUN BUILDING MATERIALS INC — Type SUPREME D24/30EQD and Type SUPREME D20

SCAFCO STEEL STUD MANUFACTURING CO — Type SUPREME D24/30EQD and Type SUPREME D20

STEEL CONSTRUCTION SYSTEMS INC — Type SUPREME D24/30EQD and Type SUPREME D20

TELLING INDUSTRIES L L C — Type SUPREME D24/30EQD and Type SUPREME D20

UNITED METAL PRODUCTS INC — Type SUPREME D24/30EQD and Type SUPREME D20

1C. **Framing Members* — Floor and Ceiling Runners** — (Not Shown) — For 1 Hour Rating, For use with Item 2C, channel shaped, min. 3-5/8 in. wide, fabricated from min. 25 MSG (0.018 in. min. bare metal thickness), attached to floor and ceiling with fasteners 24 in. OC max.

CALIFORNIA EXPANDED METAL PRODUCTS CO — Viper X Track

2. **Framing Members* — Steel Studs** — For 1 Hour Rating, channel shaped studs, min. 3-5/8 in. wide, spaced a max of 24 in. OC. Studs to be cut 3/4 in. less than assembly height.

ALLSTEEL & GYPSUM PRODUCTS INC — Type SUPREME D24/30EQD and Type SUPREME D20

CALIFORNIA EXPANDED METAL PRODUCTS CO — Viper25™

CONSOLIDATED FABRICATORS CORP, BUILDING PRODUCTS DIV — Type SUPREME D24/30EQD and Type SUPREME D20

MARINO/WARE, DIV OF WARE INDUSTRIES INC — Viper25™

FUSION BUILDING PRODUCTS — Viper25™

IMPERIAL MANUFACTURING GROUP INC — Viper25™

QUAIL RUN BUILDING MATERIALS INC — Type SUPREME D24/30EQD and Type SUPREME D20

SCAFCO STEEL STUD MANUFACTURING CO — Type SUPREME D24/30EQD and Type SUPREME D20

STEEL CONSTRUCTION SYSTEMS INC — Type SUPREME D24/30EQD and Type SUPREME D20

TELLING INDUSTRIES L L C — Viper25™

TELLING INDUSTRIES L L C — Type SUPREME D24/30EQD and Type SUPREME D20

UNITED METAL PRODUCTS INC — Type SUPREME D24/30EQD and Type SUPREME D20

2A. **Framing Members* — Steel Studs** — For 2 or 2-1/2 Hour Ratings, min. 2-1/2 in. wide, spaced a max of 24 in. OC. Studs to be cut 3/4 in. less than assembly height.

ALLSTEEL & GYPSUM PRODUCTS INC — Type SUPREME D24/30EQD and Type SUPREME D20

CONSOLIDATED FABRICATORS CORP, BUILDING PRODUCTS DIV — Type SUPREME D24/30EQD and Type SUPREME D20

QUAIL RUN BUILDING MATERIALS INC — Type SUPREME D24/30EQD and Type SUPREME D20

SCAFCO STEEL STUD MANUFACTURING CO — Type SUPREME D24/30EQD and Type SUPREME D20

STEEL CONSTRUCTION SYSTEMS INC — Type SUPREME D24/30EQD and Type SUPREME D20

TELLING INDUSTRIES L L C — Type SUPREME D24/30EQD and Type SUPREME D20

UNITED METAL PRODUCTS INC — Type SUPREME D24/30EQD and Type SUPREME D20

2B. **Framing Members* — Steel Studs** — (For use with Items 3B, 3C, 3E, 3F, and 3J only) — For 2 Hour Rating, 1-5/8 in. wide, spaced a max of 24 in. OC. Studs to be cut 3/4 in. less than assembly height.

ALLSTEEL & GYPSUM PRODUCTS INC — Type SUPREME D24/30EQD and Type SUPREME D20

CONSOLIDATED FABRICATORS CORP, BUILDING PRODUCTS DIV — Type SUPREME D24/30EQD and Type SUPREME D20

QUAIL RUN BUILDING MATERIALS INC — Type SUPREME D24/30EQD and Type SUPREME D20

SCAFCO STEEL STUD MANUFACTURING CO — Type SUPREME D24/30EQD and Type SUPREME D20

STEEL CONSTRUCTION SYSTEMS INC — Type SUPREME D24/30EQD and Type SUPREME D20

TELLING INDUSTRIES L L C — Type SUPREME D24/30EQD and Type SUPREME D20

UNITED METAL PRODUCTS INC — Type SUPREME D24/30EQD and Type SUPREME D20

2C. **Framing Members* — Steel Studs** — For 1 Hour Rating, For use with Item 1C, channel shaped studs, min. 3-5/8 in. wide, fabricated from min. 25 MSG (0.018 in. min. bare metal thickness), spaced a max of 24 in. OC. Studs to be cut 3/4 in. less than assembly height.

CALIFORNIA EXPANDED METAL PRODUCTS CO — Viper X

3. **Gypsum Board*** — For 1 Hour rating, one layer of 5/8 in. thick gypsum board applied vertically to studs with #6 x 1-1/4 in. long bugle head screws spaced 8 in. OC at the perimeter and 12 in. OC in the field of the boards. Vertical joints are staggered from vertical joints on opposite sides of the wall.

UNITED STATES GYPSUM CO — Type C

USG BORAL DRYWALL SFZ LLC — Type C

3A. **Gypsum Board*** — (As an alternate to Item 3) — For 1 Hour Rating, use one layer of 5/8 in. thick gypsum board applied vertically to studs with #6 x 1 in. long bugle head screws spaced 8 in. OC at the perimeter and 8 in. OC in the field of the boards. Vertical joints are staggered from vertical joints on opposite sides of the wall. For 2 Hour Rating (Not Shown), use two layers of 5/8 in. thick gypsum board applied horizontally. Base layer of board attached to studs with #6 x 1 in. long bugle head screws spaced 16 in. OC. starting 8 in. from the edge of the board with one screw 1-1/4 in. from the edge. Face layer of board attached to studs with #6 x 1-5/8 in. long bugle head screws spaced 16 in. OC. Starting 8 in. from the edge of the board with one screw 1-1/4 in. from the edge. Horizontal joints on the face layer are staggered 12 in. from the base layer.

CGC INC — Type SCX

UNITED STATES GYPSUM CO — Type SCX

USG BORAL DRYWALL SFZ LLC — Type SCX

USG MEXICO S A D E C V — Type SCX

3B. **Gypsum Board*** — (As an alternate to Item 3) — For 1 hr rating (Vertical application) — One layer of 5/8 in. thick gypsum board applied vertically to studs with #6 x 1-1/4 in. long bugle head screws spaced 8 in. OC at the perimeter and 12 in. OC in the field of the boards. Vertical joints are centered over studs and staggered from vertical joints on opposite sides of the wall. For 2 hr rating (Vertical application - Not Shown) — Two layers of 5/8 in. thick gypsum board applied vertically. Inner layer attached to studs with #6 x 1 in. long bugle head screws spaced 12 in. OC along the top and bottom tracks and 16 in. OC in the field and along the vertical edges. Outer layer attached to studs with #6 x 1-5/8 in. long bugle head screws spaced 12 in. OC along the top and bottom tracks and 16 in. OC in the field and along the vertical edges with screws offset 8 in. from inner layer. Vertical joints are centered over studs and staggered between layers and on opposite sides of the wall. For 2 hr rating (Horizontal application) - Two layers of 5/8 in. thick gypsum board applied horizontally. Inner layer attached to studs with #6 x 1 in. long Type S bugle head screws spaced 24 in. OC with the 1st screw installed 1-1/4 in. from the board edge and to the track only spaced 24 in. OC. Outer layer attached to studs with 1-5/8 in. long Type S bugle head screws spaced 16 in. OC with the 1st and 2nd screws installed 1-1/4 in. and 8 in. from the board edge, respectively; and to the track only spaced 16 in. OC. Horizontal joints on the face layer are staggered 12 in. from the base layer.

NATIONAL GYPSUM CO — Types eXP-C, FSK, FSK-C, FSL, FSMR-C, FSW, FSW-3, FSW-6, FSW-8, FSW-C, Type SBWB (vertical installation only)

3C. **Gypsum Board*** — (As an alternate to Item 3) — For 1 hr rating (Vertical application) — One layer of 5/8 in. thick gypsum board applied vertically to studs with #6 x 1-1/4 in. long bugle head screws spaced 8 in. OC at the perimeter and 12 in. OC in the field of the boards. Vertical joints are centered over studs and staggered from vertical joints on opposite sides of the wall. For 1 hr rating (Horizontal application) - One layer of 5/8 in. thick gypsum board attached horizontally to studs with 1 in. long Type S bugle head screws spaced 8 in. OC; and to floor and ceiling runners with 1 in. long Type S bugle head screws spaced 8 in. OC with the 1st screw 2 in. from board edge Horizontal joints need not be staggered on opposite faces or backed by steel framing. For 2 hr rating (Not Shown) - Two layers of 5/8 in. thick gypsum board applied vertically or horizontally. Inner layer attached to studs with #6 x 1 in. long bugle head screws spaced 12 in. OC along the top and bottom tracks and 16 in. OC in the field and along the vertical edges. Outer layer attached to studs with #6 x 1-5/8 in. long bugle head screws spaced 12 in. OC along the top and bottom tracks and 16 in. OC in the field and along the vertical edges. Vertical joints are centered over studs and staggered between layers and on opposite sides of the wall. Horizontal joints on the face layer are staggered 12 in. from the base layer. Horizontal joints need not to be backed by steel framing.

CONTINENTAL BUILDING PRODUCTS OPERATING CO, L L C — Types LGFC2A, LGFC6A, LGFC-C/A, LGFC-WD

3D. **Gypsum Board*** — (As an alternate to Item 3) — For 1 Hour Rating — One layer of 5/8 in. thick, 4 ft. wide, gypsum board applied vertically to studs with #6 x 1 in. long bugle head screws spaced 8 in. OC at the perimeter, starting 4 in. from the edge of the boards, and 12 in. OC in the field of the boards, starting 6 in. from the edge of the board. Vertical joints are staggered from vertical joints on opposite sides of the wall. For 2 or 2-1/2 Hour Rating - Two layers of 5/8 in. thick, 4 ft. wide, gypsum board applied vertically. Inner layer attached with #6 x 1 in. long bugle head screws spaced 12 in. OC along the top and bottom tracks with one screw located 6 in. from each edge of the board and 16 in. OC along the studs with one screw located

8 in. from one edge of the board. Outer layer attached with #6 x 1-5/8 in. long bugle head screws spaced 12 in. OC along the top and bottom tracks with one screw located 1-1/2 in. from each edge of the board and 16 in. OC along the studs with one screw located 8 in. from one edge of the board as to offset the face layer screws 8 in. from the base layer screws. Vertical joints are centered over studs and staggered between layers and on opposite sides of the wall.

AMERICAN GYPSUM CO — Types AGX-1, M-Glass, LightRoc

3E. Gypsum Board* — For 1 hr rating (Vertical application) — One layer of 5/8 in. thick gypsum board applied vertically to studs with 1 in. long Type-S bugle head screws spaced 8 in. OC at the perimeter and 12 in. OC in the field with the 1st screw installed 4 in. from the board edges at the perimeter and 6 in. from the board edge in the field. Vertical joints are centered over studs and staggered from vertical joints on opposite sides of the wall. For 1 hr rating (Horizontal application) — One layer of 5/8 in. thick gypsum board applied horizontally to studs with 1 in. long Type-S bugle head screws spaced 8 in. OC at the perimeter and in the field with the 1st screw installed 4 in. from the board edge. Horizontal joints need not be staggered on opposite faces or backed by steel framing. For 2 hr rating (Horizontal application) - Two layers of 5/8 in. thick gypsum board applied horizontally. The base layer is attached to the studs, with #6 x 1 in. long Type-S bugle head screws, spaced 16 in. OC with the 1st and 2nd screws installed 1 in. and 8 in. from the board edge, respectively; and to the track spaced 16 in. OC. with the 1st screw installed 3 in. from the board edge. The face layer attached to the studs with 1-5/8 in. long Type S bugle head screws spaced 16 in. OC. with the 1st and 2nd screws installed 1 in. and 8 in. from the board edge, respectively; and to the track spaced 16 in. OC. with the 1st and 2nd screws installed 2 in. and 11 in. from the board edge. Horizontal joints need not be staggered on opposite faces or backed by steel framing. Face layer horizontal joints must be staggered a minimum 12 in. from the base layer when applied horizontally. For 2 hr rating (Vertical application) - Two layers of 5/8 in. thick gypsum boards applied vertically. The base layer attached to the studs with #6 x 1 in. long Type-S bugle head screws, spaced 16 in. OC. with 1st screws installed 8 in. from the board edge in the field and 3 in. from the board edge in the perimeter. The face layer attached to the studs with #6 x 1-5/8 in. long Type-S bugle head screws, spaced 16 in. OC. with 1st screw installed 16 in. from the board edge in the field and 1st and 2st screws installed 2 in. and 11 in. from the board edge in the perimeter, respectively. Vertical joints are centered over studs and staggered between layers and on opposite sides of the wall.

CERTAINTED GYPSUM INC — Type C

SAINT-GOBAIN GYPROC MIDDLE EAST FZE — Type Gyproc FireStop, Gyproc FireStop MR, Gyproc FireStop M2TECH, Gyproc FireStop ACTIV'Air, Gyproc FireStop MR ACTIV'Air, Gyproc FireStop M2TECH ACTIV'Air, Gyproc DuraLine, Gyproc DuraLine MR, Gyproc DuraLine M2TECH, Gyproc DuraLine ACTIV'Air, Gyproc DuraLine MR ACTIV'Air, Gyproc DuraLine M2TECH ACTIV'Air

THAI GYPSUM PRODUCTS PCL — Type C

3F. Gypsum Board* — (As an alternate to Item 3) — For 1 hr rating (Vertical application) — One layer of 5/8 in. thick gypsum board applied vertically to studs with #6 x 1 in. long bugle head screws spaced 8 in. OC at the perimeter and 12 in. OC in the field of the boards. Vertical joints are centered over studs and staggered from vertical joints on opposite sides of the wall. For 2 hr rating (Vertical application - Not Shown) - Two layers of 5/8 in. thick gypsum board applied vertically. Inner layer attached to studs with #6 x 1 in. long bugle head screws spaced 24 in. OC along the top and bottom tracks and 24 in. OC in the field and along the vertical edges. Outer layer attached to studs with #6 x 1-5/8 in. long bugle head screws spaced 16 in. OC along the top and bottom tracks and 16 in. OC in the field and along the vertical edges. Vertical joints are centered over studs and staggered between layers and on opposite sides of the wall. For 2 hr rating (Horizontal application) — Two layers of 5/8 in. thick gypsum board applied horizontally. Inner layer attached to studs with #6 x 1 in. long Type S bugle head screws spaced 24 in. OC with the 1st screw installed 1-1/4 in. from the board edge and to the track only spaced 24 in. OC. Outer layer attached to studs with 1-5/8 in. long Type S bugle head screws spaced 16 in. OC with the 1st and 2nd screws installed 1-1/4 in. and 8 in. from the board edge, respectively; and to the track only spaced 16 in. OC. Horizontal joints on the face layer are staggered 12 in. from the base layer.

GEORGIA-PACIFIC GYPSUM L L C — For 1 hr rating Types 5, 6, 9, C, DAP, DAPC, DGG, DS, TG-C, Type X, Veneer Plaster Base - Type X, Water Rated - Type X, Sheathing - Type X, Soffit - Type X; For 2 hr rating Types 5, 6, 9, C, DAP, DAPC, DGG, DS, Type X, Veneer Plaster Base - Type X, Water Rated - Type X, Sheathing - Type X, Soffit - Type X.

3G. Gypsum Board* — (As an alternate to Item 3) — For 1 hr rating - Nom 5/8 in. thick gypsum panels with beveled, square or tapered edges, applied vertically or horizontally. Vertical joints centered over studs and staggered one stud cavity on

opposite sides of studs. Horizontal edge joints and horizontal butt joints on opposite sides of studs need not be staggered or backed by steel framing. Panels attached to steel studs and floor runner with 1 in. long Type S steel screws spaced 8 in. OC when applied horizontally, or 8 in. OC along vertical and bottom edges and 12 in. OC in the field when panels are applied vertically. When used in widths other than 48 in., gypsum panels to be installed horizontally.

CGC INC — Type ULX

UNITED STATES GYPSUM CO — Type ULX

USG MEXICO S A DE C V — Type ULX

3H. **Gypsum Board*** — (As an alternate to Item 3) — For 1 hr rating (Vertical application) — One layer of 5/8 in. thick gypsum board applied vertically to studs with #6 x 1 in. long bugle head screws spaced 8 in. OC at the perimeter and 12 in. OC in the field of the boards. Vertical joints are centered over studs and staggered from vertical joints on opposite sides of the wall. For 2 hr rating (Vertical application - Not Shown) - Two layers of 5/8 in. thick gypsum board applied vertically. Inner layer attached to studs with #6 x 1 in. long bugle head screws spaced 24 in. OC along the top and bottom tracks and 24 in. OC in the field and along the vertical edges. Outer layer attached to studs with #6 x 1-5/8 in. long bugle head screws spaced 16 in. OC along the top and bottom tracks and 16 in. OC in the field and along the vertical edges. Vertical joints are centered over studs and staggered between layers and on opposite sides of the wall.

GEORGIA-PACIFIC GYPSUM L L C — Type LWX, Veneer Plaster Base-Type LWX, Water Rated-Type LWX, Sheathing Type-LWX, Soffit-Type LWX, Type LW2X, Veneer Plaster Base - Type LW2X, Water Rated - Type LW2X, Sheathing - Type LW2X, Soffit - Type LW2X, Type DGL2W, Water Rated - Type DGL2W, Sheathing - Type DGL2W.

3I. **Gypsum Board*** — (As an alternate to 5/8 in. Type FSW in Item 3B) — Nom. 5/16 in. thick gypsum panels applied vertically or horizontally. Two layers of 5/16 in. for every single layer of 5/8 in. gypsum board described in Item 3B. Horizontal joints on the same side need not be staggered. Inner layer of each double 5/16 in. layer attached with fasteners, as described in item 3B, spaced 24 in. OC. Outer layer of each double 5/16 in. layer attached per Item 3B.

NATIONAL GYPSUM CO — Type FSW

3J. **Gypsum Board*** — (As an alternate to Item 3) — For 1 Hour Rating — One layer of 5/8 in. thick, 4 ft. wide, gypsum panels with beveled, square or tapered edges. Gypsum panels applied vertically or horizontally with joints centered over studs. Horizontal joints need not be backed by steel framing. Horizontal edge joints and horizontal butt joints on opposite sides of studs need not be staggered. When applied horizontally, gypsum panels fastened to framing with 1 in. long Type S or S-12 steel screws 1-1/2 in. from board edges, 3 in. from board edge, every 8 in. OC in the field, and 12 in. along the top and bottom edges of the wall. When applied vertically, gypsum panels fastened to framing with 1 in. long Type S or S-12 steel screws every 8 in. OC in the field and 12 in. along the top and bottom edges of the wall. For 2 hr rating - (Not Shown) - Two layers of 5/8 in thick, 4ft wide, gypsum board applied vertically or horizontally Vertical joints centered over studs and staggered one stud cavity on opposite sides of studs. Vertical joints to be staggered between layers and on opposite side of wall. Horizontal joints need not be backed by steel framing. Horizontal edge joints and horizontal butt joints on opposite sides of studs need not be staggered. Horizontal edge joints and horizontal butt joints between layers to be staggered a min of 12 in. For vertical application of gypsum board, base layer to be fastened with 1 in. screws spaced 12 in. OC and face layer to be fastened with 1-5/8 in. screws spaced 12 in. OC. For horizontal application of gypsum board, base layer to be fastened with screws spaced 16 in. OC and face layer to be fastened with 1-5/8 screws spaced 16 in. OC. In either vertical or horizontal applications, Type S or Type S-12 steel screws are to be used.

CERTAINTED GYPSUM INC — Type X-1, GlasRoc, Type Silent FX, Easi-Lite Type X-2, Type Habito

3K. **Gypsum Board*** — (As an alternate to Item 3) — For 1 hr rating — Nom 5/8 in. thick gypsum panels with beveled, square or tapered edges, applied vertically or horizontally. Minimum 3-1/2 in thick **Batts and Blankets*** (Item 5A) required. Vertical joints centered over studs and staggered one stud cavity on opposite sides of studs. Horizontal edge joints and horizontal butt joints on opposite sides of studs need not be staggered or backed by steel framing. Panels attached to steel studs and floor runner with 1 in. long Type S steel screws spaced 8 in. OC when applied horizontally, or 8 in. OC along vertical and bottom

edges and 12 in. OC in the field when panels are applied vertically. For 2 Hour Rating (Not Shown), use two layers of 5/8 in. thick gypsum board applied horizontally or vertically. Base layer of board attached to studs with 1 in. long Type S steel screws, spaced 16 in. OC. Face layer of board attached to studs with 1-5/8 in. long Type S steel screws, spaced 8 in. OC. Horizontal joints between inner and outer layers need not be staggered. When used in widths other than 48 in., gypsum panels to be installed horizontally.

CGC INC — Type ULIX

UNITED STATES GYPSUM CO — Type ULIX.

3L. **Gypsum Board*** — (As an alternate to Items 3 through 3K) — Nominal 5/8 in. thick, 4 ft wide panels, applied vertically only and fastened to the studs and plates with 1 in. long, Type S steel screws spaced, 12 in. OC.

NATIONAL GYPSUM CO — Type SBWB

3M. **Gypsum Board*** — (As an alternate to Item 3, for use with Item 5) — For 1 Hour Rating — One layer of 5/8 in. thick, 4 ft. wide, gypsum panels with beveled, square or tapered edges. Gypsum panels applied vertically or horizontally with joints centered over studs. Horizontal joints need not be backed by steel framing. Horizontal edge joints and horizontal butt joints on opposite sides of studs need not be staggered. When applied horizontally, gypsum panels fastened to framing with 1 in. long Type S or S-12 steel screws 1-1/2 in. from board edges, 3 in. from board edge, every 8 in. OC in the field, and 12 in. along the top and bottom edges of the wall. When applied vertically, gypsum panels fastened to framing with 1 in. long Type S or S-12 steel screws every 8 in. OC in the field and 12 in. along the top and bottom edges of the wall. For 2 hr rating - (Not Shown) - Two layers of 5/8 in thick, 4ft wide, gypsum board applied vertically or horizontally Vertical joints centered over studs and staggered one stud cavity on opposite sides of studs. Vertical joints to be staggered between layers and on opposite side of wall. Horizontal joints need not be backed by steel framing. Horizontal edge joints and horizontal butt joints on opposite sides of studs need not be staggered. Horizontal edge joints and horizontal butt joints between layers to be staggered a min of 12 in. For vertical application of gypsum board, base layer to be fastened with 1 in. screws spaced 12 in. OC and face layer to be fastened with 1-5/8 in. screws spaced 12 in. OC. For horizontal application of gypsum board, base layer to be fastened with screws spaced 16 in. OC and face layer to be fastened with 1-5/8 screws spaced 16 in. OC. In either vertical or horizontal applications, Type S or Type S-12 steel screws are to be used.

CERTAINTED GYPSUM INC — Easi-Lite Type X

3N. **Gypsum Board*** — (As an alternate to Item 3, for 1 hr. rating) — Nom. 5/8 in. thick gypsum panels applied vertically or horizontally. Horizontal edge joints and horizontal butt joints on opposite sides of studs need not be staggered or backed by steel framing. Gypsum panels fastened to framing with 1 in. long Type S steel screws 12 in. OC along vertical edges and in the field. Screws spaced a max 12 in. along the top and bottom edges of the wall for both vertical and horizontal applications.

NATIONAL GYPSUM CO — Types eXP-C, FSK, FSK-C, FSK-G, FSL, FSW-C, FSW-G, FSW, FSW-3, FSW-5, FSW-6, FSMR-C

3O. **Gypsum Board*** — (As an alternate to Item 3) — **For 1 hr rating (Vertical application)** — One layer of 5/8 in. thick gypsum board applied vertically to studs with #6 x 1 in. long bugle head screws spaced 8 in. OC at the perimeter and 12 in. OC in the field of the boards. Vertical joints are centered over studs and staggered from vertical joints on opposite sides of the wall. **For 2 hr rating (Vertical application - Not Shown)** - Two layers of 5/8 in. thick gypsum board applied vertically. Inner layer attached to studs with #6 x 1 in. long bugle head screws spaced 24 in. OC along the top and bottom tracks and 24 in. OC in the field and along the vertical edges. Outer layer attached to studs with #6 x 1-5/8 in. long bugle head screws spaced 16 in. OC along the top and bottom tracks and 16 in. OC in the field and along the vertical edges. Vertical joints are centered over studs and staggered between layers and on opposite sides of the wall. **For 2 hr rating (Horizontal application)** — Two layers of 5/8 in. thick gypsum board applied horizontally. Inner layer attached to studs with #6 x 1 in. long Type S bugle head screws spaced 24 in. OC with the 1st screw installed 1-1/4 in. from the board edge and to the track only spaced 24 in. OC. Outer layer attached to studs with 1-5/8 in. long Type S bugle head screws spaced 16 in. OC with the 1st and 2nd screws installed 1-1/4 in. and 8 in. from the board edge, respectively; and to the track only spaced 16 in. OC. Horizontal joints on the face layer are staggered 12 in. from the base layer.

PABCO BUILDING PRODUCTS L L C, DBA PABCO GYPSUM — Type PGI

4. **Joint Tape and Compound** — Vinyl or casein, dry or premixed joint compound applied in two coats to outer layer joints and screw heads. Paper tape, nom 2 in. wide, embedded in first layer of compound over all joints.

5. **Batts and Blankets*** — (Optional, Not Shown) — Friction fit in stud cavities, any glass fiber or mineral wool insulation bearing the UL Classification Marking as to Fire Resistance. See Batts and Blankets (BZJZ) for names of Classified companies. Required when used with Item 3M.

5A. **Batts and Blankets*** — For use with Item 3K. Placed in stud cavities, any min. 3-1/2 in. thick glass fiber insulation bearing the UL Classification Marking as to Surface Burning Characteristics and/or Fire Resistance. See **Batts and Blankets (BKNV or BZJZ) Categories** for names of Classified companies.

6. **Resilient Channels** — (Optional, Not Shown) — Resilient furring channels fabricated from min. 25 MSG corrosion-protected steel, spaced vertically a max of 24 in. OC. flange portion attached to each intersecting stud with 1/2 in. long Type S-12 pan-head steel screws.

*** Indicates such products shall bear the UL or cUL Certification Mark for jurisdictions employing the UL or cUL Certification (such as Canada), respectively.**

Last Updated on 2020-12-01

The appearance of a company's name or product in this database does not in itself assure that products so identified have been manufactured under UL's Follow-Up Service. Only those products bearing the UL Mark should be considered to be Certified and covered under UL's Follow-Up Service. Always look for the Mark on the product.

UL permits the reproduction of the material contained in the Online Certification Directory subject to the following conditions: 1. The Guide Information, Assemblies, Constructions, Designs, Systems, and/or Certifications (files) must be presented in their entirety and in a non-misleading manner, without any manipulation of the data (or drawings). 2. The statement "Reprinted from the Online Certifications Directory with permission from UL" must appear adjacent to the extracted material. In addition, the reprinted material must include a copyright notice in the following format: "© 2020 UL LLC"